

Section 1800 Index

CHAIN LUBRICATION.....38

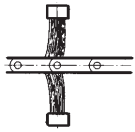

General and engineering data helpful in determining your lubricating requirements.

STANDARD CHAIN LUBRICATION SYSTEMS39

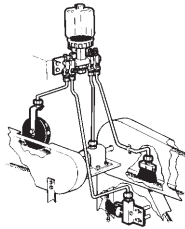

Central reservoir dispensing oil to one or more points.

ELECTRO CHAIN LUBRICATORS40



Automatic electro chain lubricators are especially suitable for intermittent operation. They are turned on and off automatically with a solenoid valve.

MANUAL CHAIN LUBRICATORS.....41



Manual chain lubricators are ideal for continuous operation. They are turned on and off with a toggle shut-off.

SHANK BRUSH DISPENSERS42



Consist of a central oiler with single or multiple feed valves.

SHANK BRUSHES43



Consist of brushes attached to holders.

VALVE BRUSH DISPENSERS.....44



Consist of a central full flow dispenser.

VALVE BRUSHES45



Consist of a metering valve with sight which is then connected to various styles of brushes.

SPARE PARTS AND ACCESSORIES46-47



HELPFUL HINTS ON OPERATION AND MAINTENANCE48

Chain Lubrication

Chain Lubrication

All chains should be lubricated in order to protect a costly investment. You will profit by the recommendations made, since chain life will be increased many times. Even under dusty and abrasive conditions, lubrication is recommended. Only when it is impossible to lubricate should a chain be operated dry at a sacrifice in chain life.

The primary purpose of chain lubrication is to provide a film of oil at all load carrying points where motion occurs. This will reduce friction, minimize wear, stretch, corrosion, and reduce power consumption. Benefits obtained will pay for the lubricating equipment in a very short time.

The proper selection of equipment for dispensing the lubricant to the wearing surfaces of the chain is of prime importance. Many factors influence the choice of equipment shown in this brochure. The selection of a suitable lubricant is equally important, and we suggest you consult your oil company.

Helpful Engineering Data

$$S = \frac{T \times P \times N}{12}$$

$$Dp = \frac{P \times T}{3.14}$$

$$L = \frac{33000 \times H}{S}$$

T = Number of teeth driving sprocket
 N = RPM of driving sprocket
 Dp = Pitch dia. of driving sprocket
 S = Chain speed in feet per minute
 P = Chain pitch in inches
 H = Horsepower
 L = Chain pull in pounds

Power Drive Chains

The amount and type of lubrication are governed by the type of chain and operating conditions. The lubrication needed will depend upon friction and heat. All power drive chains create heat, some considerable, some little. Generally, the operating temperature should not exceed 160° F.

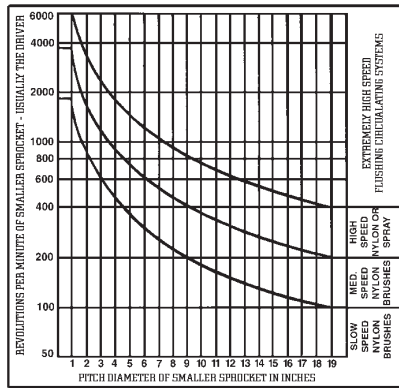

Fig. 1.

Proper lubricating methods for power drive chains can be divided into four areas, and selected from chart Fig. 1.

1. Determine pitch diameter in inches of the small sprocket.
2. Determine revolutions per minute of the small sprocket.
3. Extend lines from pitch diameter and RPM. The area in which these lines

meet will indicate the lubricating method.

The recommended methods of chain lubrication are:

1. Slow to medium speed area.
Use brush lubricator with nylon brushes.
2. High speed area.
Use brush lubricator with nylon brushes or spray system for best wearing qualities.
3. Extremely high speed area.
Use force feed oiling system to carry away heat.

Conveyor and Elevator Chains

The lubrication of these chains depends upon many factors, and operating conditions usually govern the method of lubrication. We will be glad to make specific recommendations for individual applications.

Many methods of lubrication may be used which in most cases depend on the nature of the surrounding atmosphere. Clean atmosphere may permit the use of brush type lubrication. The existence of lint or non-abrasive dust

suggests the use of chain cleaners, followed by brush lubricating. Chain cleaners are strongly recommended when abrasive conditions exist, and oiling even in these cases is considered advantageous as it will prolong chain life.

Chains operating at elevated temperatures (above 250° F) can be lubricated by brush oilers with stainless steel brushes, or with stainless steel wire wheel brushes, which are rotated by the chain, transferring oil from a pan to the underside of the chains. Spraying is also widely used to lubricate "hot" chains.

Special methods of lubrication should be found, if possible, for chains which come in contact with material being handled. These problems are sometimes very difficult as the material itself might be very sensitive or prohibit the use of oil or grease.

Chain Brush Lubrication

The use of a brush is the most effective and reliable method of chain lubrication, avoiding excess oil, dripping and slippery floors. The bristles of a brush are flexible and will follow the contour of the moving chain thus spreading and distributing oil to essential high and low points.

A brush will also perform a cleaning action in addition to oiling. Accumulated dirt and old lubricants are wiped off automatically. Brush type lubrication therefore accomplishes the dual function of oiling as well as cleaning. Oil-Rite's brush type lubricators are adaptable to most equipment. They may be selected from many styles, and if only a small space is available, components can be installed separately and connected with tubing.

Brushes for general purpose use have specially selected bristles for oil retention and good wear. They are normally furnished with all regular catalog items. Crimped black nylon brushes are available for greater wear resistance, longer life and are recommended for high speed chains. Crimped stainless steel brushes can be used for lubricating high temperature chains (above 250° F) as well as for cleaning. Selection of brush size and mounting:

1. Select lubricator with a brush size wide enough to almost cover the chain width.
2. Whenever possible locate brush on the inside surface of the chain, so oil will penetrate chain links by centrifugal force.
3. Brushes should ride the chain at a point where there is a minimum of sway to prevent damage to the brush.
4. Rotate brushes occasionally and adjust to compensate for wear. Provision is made on nearly all units for a minimum of 1/2" brush wear.

Chain Cleaning

Chains operating in dusty and dirty surroundings should be cleaned periodically. Complete removal of chains for cleaning purposes is not necessary as chains can effectively be cleaned automatically without removal.

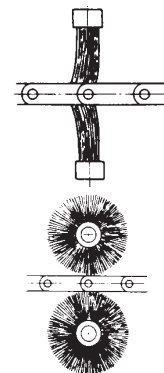

Stainless Steel Brushes

Brushes with stainless steel bristles suitably mounted offer one method of chain cleaning. Care should be taken to install the brushes at a point where chains sway is at a minimum.

Wire Wheel Brushes

Wire wheel brushes are ideal for cleaning chains. They can be mounted on opposite sides of the chain and rotated by the chain itself, thus cleaning it automatically.

Write us for recommendations regarding chain lubrication for your machinery. You can benefit from practical ideas tested and successfully used by others.

CHAIN LUBRICATORS dispense liquid by gravity from a reservoir to an integral brush through an adjustable needle valve. Available with manual or electro shutoff.

These units have an adjustable liquid feed rate which is observed through the lower sight chamber. Flow to brush is controlled by either the manual shutoff or by wiring a solenoid valve across the line of the drive motor, providing automatic operation. The flexible bristles of the brush follow the contour of the moving chain and spread liquid to all load-bearing points. Brushes can be adjusted for wear and can be readily replaced.

Reservoirs are transparent, break-resistant, high temperature plastic which allows quick visual check of liquid supply. A $\frac{5}{8}$ -18 threaded mounting shank is provided with each unit.

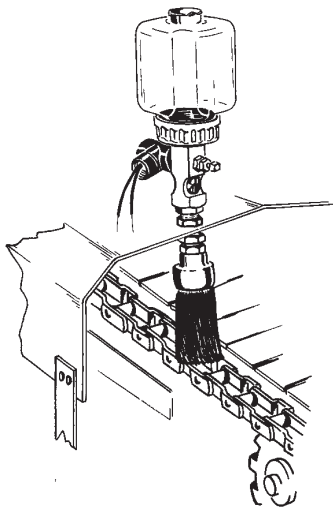

Single Chain Lubricators Consist of:

- A. Complete System—External piping is not required. Simply mount lubricator at a position where there is a minimum amount of chain sway. (Accessories shown on **Page 46**).

SINGLE LINE SYSTEMS manually or solenoid actuated, these systems are designed to operate with a central reservoir. Connected in series with a single line or pipe, it dispenses liquid by gravity from a full flow dispenser to a valve brush, Style SFGC.

Shutting off liquid supply on dispenser will immediately stop the flow of liquid to the valve brush eliminating danger of reaching into drives in hazardous quarters. Remote mounting of brushes permit installation in narrow quarters. A single dispenser for gravity feeding will feed up to 24 valve brushes. Pressure dispensers can feed as many as 60 valve brushes from a single line. Brushes can be adjusted for wear and can be readily replaced.

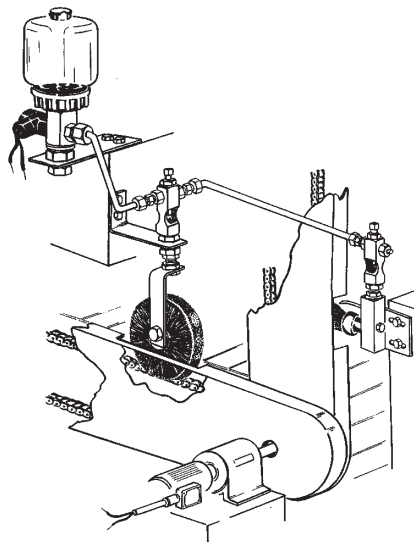

Single Line System Consists of:

- A. Central Dispenser
Select capacity in Style DEF or DFF to suit. Example: Cat. No. B-1734-4, (Shown on **Page 44**).
- B. Valve Brush, Style SFGC
Select any one or combination
Specify: Model Number
Nylon or Stainless Steel Bristles.
- C. Tubing and Fittings
To connect dispenser to valve brushes. (Accessories shown on **Page 46**).

MULTIPLE LINE SYSTEMS release liquid from a centralized dispenser through multiple needle valves.

These systems supply liquid to widely separated points. They are controlled, observed and filled from one central station which eliminates danger of reaching into drives or hazardous quarters. Shutting off of liquid supply at central dispenser will immediately stop liquid flow to valves. However, the liquid which remains in the tubing will dispense to brushes.

Central dispensers can be equipped with 2 to 24 sight feed valves. Oil-Rite's new manifold multiple feed valve systems are very versatile and sturdy in construction. This exclusive and unique feature allows for the first time, the option of changing the manifold arrangement in the field by merely stacking them together. Each feed valve can be separately adjusted and the setting retained. Manual and solenoid controlled models are available.

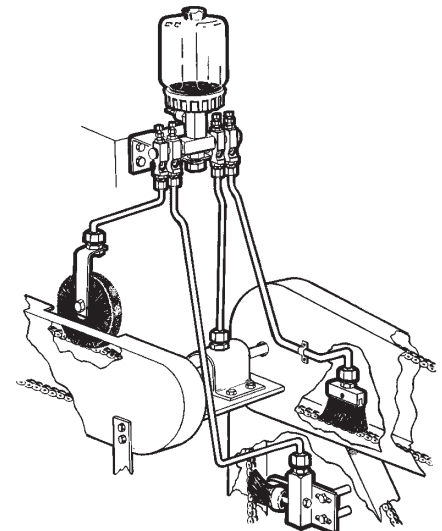

Multiple Line Systems Consists of:

- A. Central Dispenser
Select capacity in Style DE or DM to suit. Example: Electro Lubricator, Cat. No. B-3192-3, (Shown on **Page 42**) 1 Qt. Cap., 120 Volts, 60 Hz. 4 Feed Outlets.
- B. Shank Brush, Style SFCL (**Page 43**).
Select any one or combination
Specify: Model Number
Nylon or Stainless Steel Bristles.
- C. Tube Fittings
To connect multiple feed outlets of central dispenser to each shank brush. (Accessories shown on **Page 46**).

Chain Lubricators

ELECTRO CHAIN LUBRICATORS WITH BRUSHES are especially suitable for intermittent operations. They are turned on and off automatically with a solenoid valve which is wired across the line of the chain drive motor. The solenoid can also be operated by a separate switch or timer for intermittent use.

Liquid is fed to brushes by gravity through a solenoid valve. It is then fed to an adjustable precision needle valve with a friction lock, which guards against loosening from vibration. Drop feeding can be observed through the viewing window in the mounting shank.

The flexible bristles of the brush follow the contour of the moving chain and spread liquid to all load-carrying points. This results in a reduction of chain wear which prolongs the life of costly chains. Lubrication occurs only when the chain moves through the brush riding on the chain. For typical installation, see page 39.

SPECIFICATIONS:

- Pressure Atmospheric Pressure
Gravity Feed Only
Reservoir and Sight Are Vented
- Temperature 160° F. Max. Acrylic
225° F. Max. Pyrex or Polycarbonate
Adjustable Needle Valve with Solenoid Shutoff
- Metering
- Reservoir Acrylic, Polycarbonate or Pyrex
- Valve Body Aluminum Alloy
- Seals Buna-N
- Sight Glass
- Covers Aluminum Alloy or Polypropylene



Style DEC



Style DEC

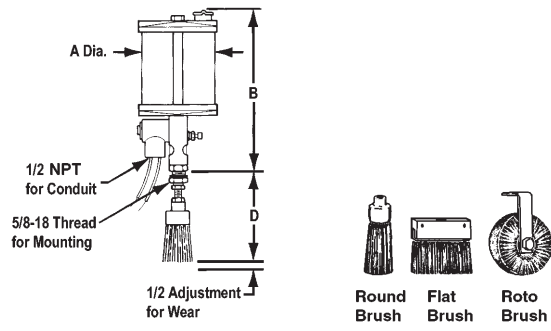
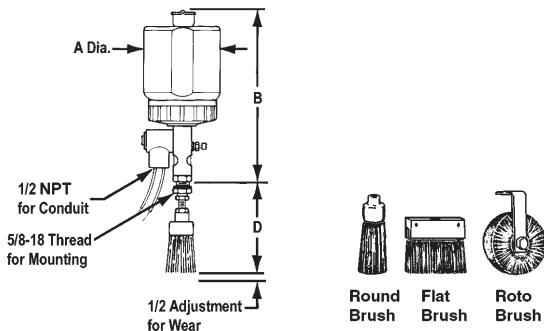

When Ordering Specify:

- Model Number
- Voltage and Frequency
- Brush Type, Size and Material (Nylon or Stainless Steel)

When Ordering Specify:

- Model Number
- Voltage and Frequency
- Brush Type, Size and Material (Nylon or Stainless Steel)

Model Number	Capacity	A	B
B-1743-1	1 OZ.	2	5
B-1743-2	2 1/2 OZ.	2	6
B-1743-3	5 OZ.	2 7/8	5 15/16
B-1743-4	9 OZ.	2 7/8	7 3/16
B-1743-5	1 PT.	3 5/8	8 1/2
B-1743-6	1 QT.	3 5/8	11 7/8
B-1743-7	1 1/2 GAL.	5	12 3/4

Model Number		Capacity	A	B
Acrylic	Pyrex			
* B-2192-2	B-2192-12	2 1/2 OZ.	2	5 9/16
* B-2192-3	B-2192-13	5 OZ.	2 1/2	6 1/16
* B-2192-4	B-2192-14	9 OZ.	3	7
B-2192-5	B-2192-15	1 PT.	3 1/2	8
B-2192-6	B-2192-16	1 QT.	4 1/4	9 5/16
B-2192-7	B-2192-17	1 1/2 GAL.	5 1/2	11 7/16
B-2192-8	—	1 GAL.	5 1/2	16 7/16

Brush Size	Round Brush				Flat Brush	Roto Brush
	1/4 Dia	5/8 Dia	1 Dia	1 1/2 Dia	2 1/4 x 3/8	3 Dia. x 1 Wide
D	3 5/8	3 1/16	3 3/4	3 3/4	3	4 7/8

Brush Size	Round Brush				Flat Brush	Roto Brush
	1/4 Dia	5/8 Dia	1 Dia	1 1/2 Dia	2 1/4 x 3/8	3 Dia. x 1 Wide
D	3 5/8	3 1/16	3 3/4	3 3/4	3	4 7/8

* Special - Please Consult Factory

MANUAL CHAIN LUBRICATORS WITH BRUSHES are ideal for continuous operation. They are turned on and off with a toggle shutoff and liquid is dispensed through a brush riding the chain.

Liquid is fed to brushes by gravity through an adjustable precision needle valve with a friction lock, which guards against loosening from vibration. The toggle shutoff is used to start and stop liquid flow, but will not affect the metering adjustment. Drop feeding can be observed through the viewing window in the mounting shank.

The flexible bristles of the brush follow the contour of the moving chain and spread liquid to all load-carrying points. This results in a reduction of chain wear which prolongs the life of costly chains. Any desired amount of liquid will be spread evenly on the chain assuring positive lubrication. For typical installation, see **page 39**.

SPECIFICATIONS:

- Pressure Atmospheric Pressure
Gravity Feed Only
Reservoir and Sight Are Vented
- Temperature 160° F. Max. Acrylic
225° F. Max. Pyrex or Polycarbonate
- Metering Adjustable Needle Valve with Toggle Shutoff
- Reservoir Acrylic, Polycarbonate or Pyrex
- Valve Body Aluminum Alloy
- Seals Buna-N
- Sight Glass
- Covers Aluminum Alloy or Polypropylene



Style DOSC



Style DOSC

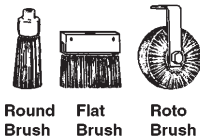
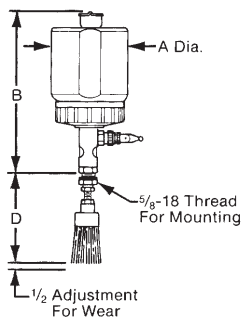

When Ordering Specify:

- Model Number
- Brush Type, Size and Material (Nylon or Stainless Steel)

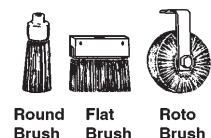
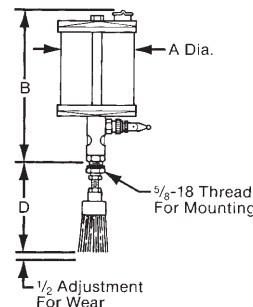

When Ordering Specify:

- Model Number
- Brush Type, Size and Material (Nylon or Stainless Steel)

Model Number	Capacity	A	B
B-1745-1	1 OZ.	2	4 1/2
B-1745-2	2 1/2 OZ.	2	5 1/2
B-1745-3	5 OZ.	2 7/8	5 7/16
B-1745-4	9 OZ.	2 7/8	6 11/16
B-1745-5	1 PT.	3 5/8	8
B-1745-6	1 QT.	3 5/8	11 3/8
B-1745-7	1/2 GAL.	5	12 1/4

Brush Size	Round Brush				Flat Brush	Roto Brush
	1/4 Dia	5/8 Dia	1 Dia	1 1/2 Dia	2 1/4 x 3/8	3 Dia. x 1 Wide
D	3 5/8	3 1/16	3 3/4	3 3/4	3	4 7/8

Model Number		Capacity	A	B
Acrylic	Pyrex			
* B-2191-2	B-2191-12	2 1/2 OZ.	2	5
* B-2191-3	B-2191-13	5 OZ.	2 1/2	5 1/2
* B-2191-4	B-2191-14	9 OZ.	3	6 7/16
B-2191-5	B-2191-15	1 PT.	3 1/2	7 7/16
B-2191-6	B-2191-16	1 QT.	4 1/4	8 3/4
B-2191-7	B-2191-17	1/2 GAL.	5 1/2	10 7/8
B-2191-8	—	1 GAL.	5 1/2	15 7/8

Brush Size	Round Brush				Flat Brush	Roto Brush
	1/4 Dia	5/8 Dia	1 Dia	1 1/2 Dia	2 1/4 x 3/8	3 Dia. x 1 Wide
D	3 5/8	3 1/16	3 3/4	3 3/4	3	4 7/8

* Special - Please Consult Factory

Shank Brush Dispensers

SHANK BRUSH DISPENSERS consist of a central lubricator with single or multiple feed valves and copper or plastic tubing which connects to shank brushes.

This system allows single or multiple chain lubrication from one reservoir. Remote mounting of brushes permit installation in extremely narrow quarters. Drop feeding is controlled by feed valves directly beneath central lubricator, thus eliminating danger of reaching into drives in hazardous quarters. Shutting off liquid supply on central lubricator will immediately stop drop feeding of valves. The liquid which remains in the tubing, however, will dispense to brushes. Central lubricators can be equipped with 1 to 24 feed outlets. Manual or automatic solenoid valve controlled models are available.

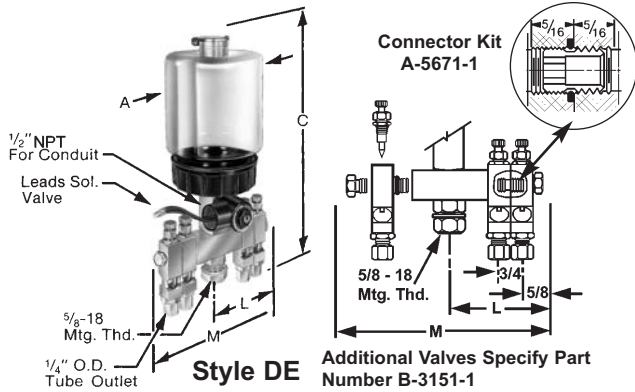

Model Number	Capacity	A	C
B-3192-2	9 OZ.	2 ⁷ / ₈	9 ¹ / ₁₆
B-3192-3	1 PT.	3 ⁵ / ₈	10 ¹ / ₁₆
B-3192-4	1 QT.	3 ⁵ / ₈	13 ⁷ / ₁₆
B-3192-5	1/2 GAL.	5	14 ¹ / ₈

For Additional information See Section 1000

Feeds	2	3	4	5	6	12	24
L	2 ¹ / ₈	2 ¹ / ₈	2 ⁷ / ₈	2 ⁷ / ₈	3 ⁵ / ₈	5 ⁷ / ₈	10 ³ / ₈
M	4 ¹ / ₄	5	5 ³ / ₄	6 ¹ / ₂	7 ¹ / ₄	11 ³ / ₄	20 ³ / ₄

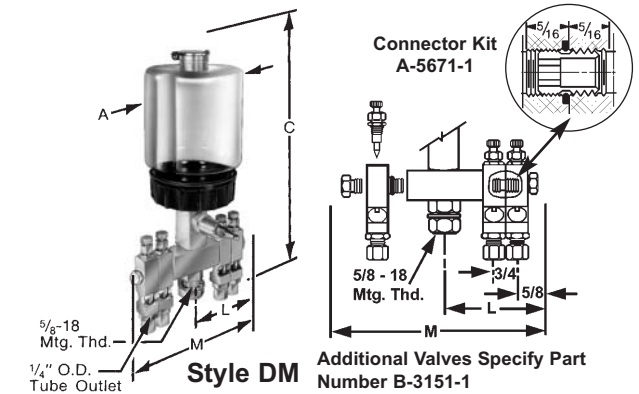

Model Number	Capacity	A	C
B-3193-2	9 OZ.	2 ⁷ / ₈	9 ¹ / ₁₆
B-3193-3	1 PT.	3 ⁵ / ₈	10 ¹ / ₁₆
B-3193-4	1 QT.	3 ⁵ / ₈	13 ⁷ / ₁₆
B-3193-5	1/2 GAL.	5	14 ¹ / ₈

For Additional information See Section 1000

Feeds	2	3	4	5	6	12	24
L	2 ¹ / ₈	2 ¹ / ₈	2 ⁷ / ₈	2 ⁷ / ₈	3 ⁵ / ₈	5 ⁷ / ₈	10 ³ / ₈
M	4 ¹ / ₄	5	5 ³ / ₄	6 ¹ / ₂	7 ¹ / ₄	11 ³ / ₄	20 ³ / ₄

SPECIFICATIONS:

- Pressure: Atmospheric Pressure, Gravity Feed Only, Reservoir and Sight Are Vented, 225° F. Max.
- Temperature: Adjustable Needle Valve with Solenoid or Toggle Shutoff
- Metering: Polycarbonate
- Reservoir: Steel, Plated or Aluminum Alloy
- Valves: Buna-N
- Seals: Glass
- Sight: Polypropylene
- Covers: Aluminum Alloy
- Body: Buna-N (Other Material Available)
- Connector Kit

When Ordering Specify:

- Model or Catalog Number
- Voltage and Frequency (If Applicable)
- Number of Feeds (2 - 24, If Applicable)

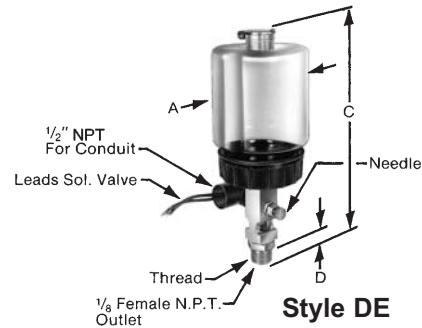

Model Number	Capacity	Outlet Thread Size	A	C	D
* B-1763-12	1 OZ.	5/8-18 N.F. FOR REMOTE MOUNTING WITH 1/8 FEMALE N.P.T. OUTLET	2	5 ⁹ / ₁₆	5/8
* B-1763-13	2 1/2 OZ.		2	6 ⁹ / ₁₆	5/8
B-1763-14	5 OZ.		2 ⁷ / ₈	6 ⁹ / ₁₆	5/8
B-1763-15	9 OZ.		2 ⁷ / ₈	7 ¹³ / ₁₆	5/8
B-1764-5	1 PT.		3 ⁵ / ₈	9 ¹ / ₈	5/8
B-1764-6	1 QT.		3 ⁵ / ₈	12 ¹ / ₂	5/8
B-1764-8	1/2 GAL.		5	13 ³ / ₈	5/8

For Additional information See Section 1000

* Special - Please Consult Factory



Model Number	Capacity	Outlet Thread Size	A	C	D
B-1681-12	1 OZ.	5/8-18 N.F. FOR REMOTE MOUNTING WITH 1/8 FEMALE N.P.T. OUTLET	2	5 ¹ / ₁₆	5/8
B-1681-13	2 1/2 OZ.		2	6 ¹ / ₁₆	5/8
B-1681-14	5 OZ.		2 ⁷ / ₈	6	5/8
B-1681-15	9 OZ.		2 ⁷ / ₈	7 ¹ / ₄	5/8
B-1682-5	1 PT.		3 ⁵ / ₈	8 ⁵ / ₈	5/8
B-1682-6	1 QT.		3 ⁵ / ₈	12	5/8
B-1682-8	1/2 GAL.		5	12 ⁷ / ₈	5/8

For Additional information See Section 1000

Shank Brushes

SHANK BRUSHES consist of brushes attached to holders. Mounting means are provided. Brushes can be adjusted for wear on most models and can easily be replaced at low cost. All shank brushes can be supplied with nylon or stainless steel bristles.

SPECIFICATIONS:

- Temperature Above 250° F. use Stainless Steel Brush
- Adapters Aluminum Alloy
- Brackets Steel, Plated
- Brushes Nylon or Stainless Steel

When Ordering Specify:

- Shank Brushes
- Model Number
- Bristle Material

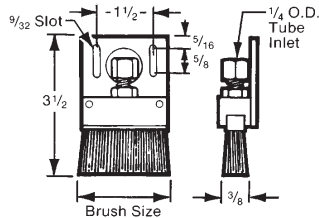

Style SFCL

Model Number	Brush Size
A-2048-1	2 1/4 x 3/8

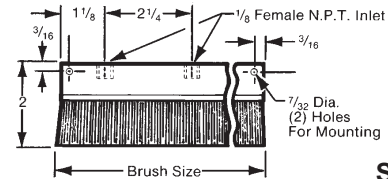

Style SFCL

Model Number	Brush Size	No. of Inlets
A-2258-1	2 1/4 x 3/8	1
A-2258-2	4 1/2 x 3/8	2
* A-2258-3	6 3/4 x 3/8	3
* A-2258-4	9 x 3/8	4
* A-2258-5	11 1/4 x 3/8	5

* Special - Please Consult Factory

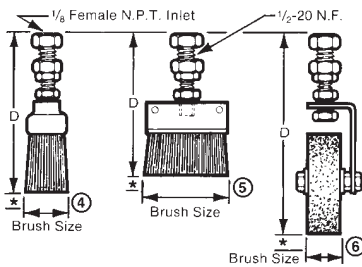

Style SFCL

* 1/2" Adjustment for wear

Model Number	Figure	Brush Size	D
A-2256-1	4	1/4 Dia.	4 1/8
A-2256-2		5/8 Dia.	3 9/16
A-2256-3		1 Dia.	4 1/4
A-2256-4		1 1/2 Dia.	4 1/4
A-2256-5	5	2 1/4 x 3/8	3 1/2
A-2256-6	6	3 Dia. x 1	5 3/8

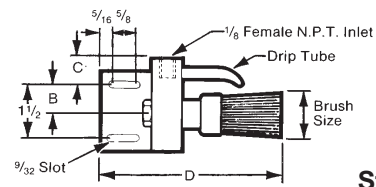

Style SFCL

Model Number	Brush Size	B	C	D
A-2260-1	1/4 Dia.	1/4	3/4	4 13/16
A-2260-2	5/8 Dia.			4 1/4
A-2260-3	1" Dia.	3/4	1	4 15/16
A-2260-4	1 1/2 Dia.			3 1/2
A-2260-5	2 1/4 x 3/8			

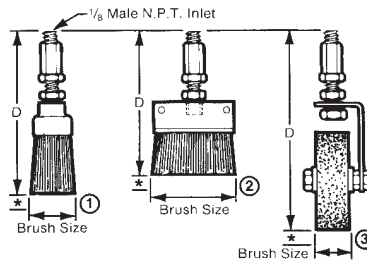

Style SFCL

* 1/2" Adjustment for wear

Model Number	Figure	Brush Size	D
A-2257-1	1	1/4 Dia.	4
A-2257-2		5/8 Dia.	3 7/16
A-2257-3		1 Dia.	4 1/8
A-2257-4		1 1/2 Dia.	4 1/8
A-2257-5	2	2 1/4 x 3/8	3 3/8
A-2257-6	3	3 Dia. x 1	5 1/4

Valve Brush Dispensers

VALVE BRUSH DISPENSERS consist of a central full flow dispenser and copper or plastic tubing which is then connected to valve brushes.

These systems allow single or multiple chain lubrication from one reservoir. Remote mounting of brushes permit installation in narrow quarters. Shutting off liquid supply on dispenser will immediately stop drop feeding to valve brush. The valve brushes can be fed at an extremely slow rate for application demanding a minimum liquid film on chains. A single dispenser for gravity feeding will feed up to 24 valve brushes. Manual or solenoid controlled models are available.

SPECIFICATIONS

Full Flow Dispensers:

- Pressure Atmospheric Pressure
Gravity Feed Only
Reservoir is Vented
- Temperature 225° F. Max.
- Metering Full Flow with Solenoid or Toggle Shutoff
1/4 Dia.
- Port Polycarbonate
- Reservoir Buna-N
- Seals Aluminum Alloy
- Shank Polypropylene
- Cover Steel, Plated
- Filler Cap

When Ordering Specify:

- Model or Catalog Number
- Voltage and Frequency (if Applicable)

SPECIFICATIONS

Air Operated Dispensers:

- Pressure 30 P.S.I. Max.
- Temperature 160° F. Max. for Acrylic
225° F. Max. for Steel
- Air Capacity 5 C.F.M. at 20 P.S.I.
- Liquid Capacity 3 G.P. H. at 10 P.S.I.
- Components Externally Mounted
Clear Acrylic or Steel,
Painted
- Reservoir Aluminum Alloy
- Covers Buna-N
- Seals

When Ordering Specify:

- Catalog Number

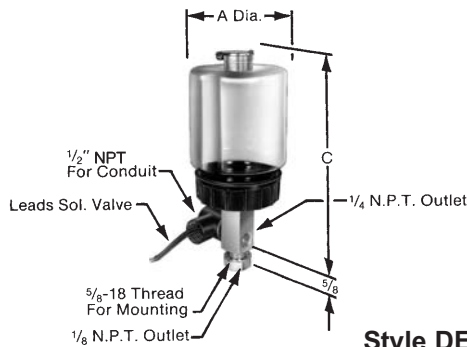

Style DEF

Model Number	Capacity	A	C
B-1733-1	1 OZ.	2	4 ³ / ₁₆
B-1733-2	2 ¹ / ₂ OZ.	2	5 ³ / ₁₆
B-1733-3	5 OZ.	2 ⁷ / ₈	5 ¹ / ₈
B-1733-4	9 OZ.	2 ⁷ / ₈	6 ³ / ₈
B-1733-5	1 PT.	3 ⁵ / ₈	7 ¹¹ / ₁₆
B-1733-6	1 QT.	3 ⁵ / ₈	11 ¹ / ₁₆
B-1733-7	1/2 GAL.	5	11 ¹⁵ / ₁₆

For Additional information See Section 1000

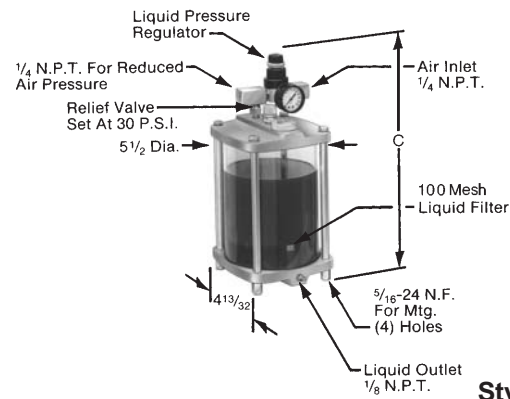

Style DHP

Catalog Number	Capacity	C
* B-1318-1	1 QT.	8 ³ / ₄
B-1318-2	1/2 GAL.	12 ¹ / ₄
B-1318-3	1 GAL.	17 ¹ / ₄
* B-1318-4	2 GAL.	30 ¹ / ₄

For Additional information See Section 1000

Manual Shutoff

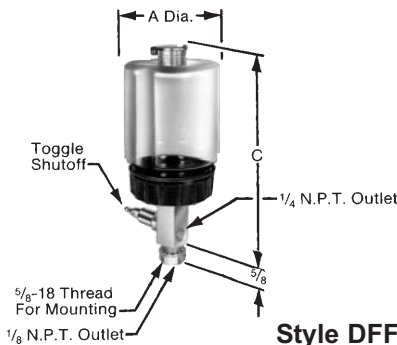

Style DFF

Catalog Number	Capacity	A	C
B-1734-1	1 OZ.	2	4 ³ / ₁₆
B-1734-2	2 ¹ / ₂ OZ.	2	5 ³ / ₁₆
B-1734-3	5 OZ.	2 ⁷ / ₈	5 ¹ / ₈
B-1734-4	9 OZ.	2 ⁷ / ₈	6 ³ / ₈
B-1734-5	1 PT.	3 ⁵ / ₈	7 ¹¹ / ₁₆
B-1734-6	1 QT.	3 ⁵ / ₈	11 ¹ / ₁₆
B-1734-7	1/2 GAL.	5	11 ¹⁵ / ₁₆

For Additional information See Section 1000

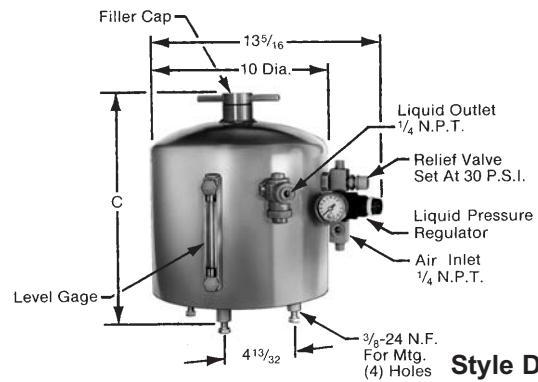

Style DHP

Catalog Number	Capacity	C
* B-1266-1	2 ¹ / ₂ GAL.	12 ¹ / ₂
* B-1266-2	5 GAL.	20 ¹ / ₂

For Additional information See Section 1000

* Special - Please Consult Factory

Valve Brushes

VALVE BRUSHES consist of a metering valve with sight which is then connected to various styles of brushes. A mounting means is provided. Brushes can be adjusted for wear and are easily replaceable at low cost. All valve brushes can be supplied with nylon or stainless steel bristles.

SPECIFICATIONS:

- Temperature Above 250° F. use Stainless steel Brush
- Adapters Aluminum Alloy
- Brackets Steel, Plated
- Brushes Nylon or Stainless Steel
- Valve Body Steel, Plated
- Seals Buna-N

When Ordering Specify:

- Valve Brushes
- Model Number
- Bristle Material

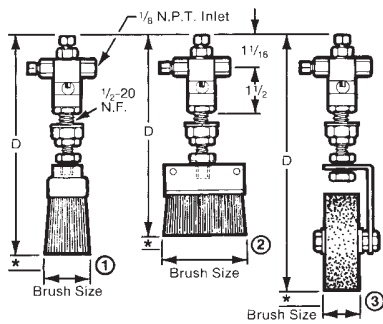

* 1/2" Adjustment for wear

Style SFGC

Model Number	Figure	Brush Size	D
A-2261-1	1	1/4 Dia.	6 ⁵ / ₁₆
A-2261-2		5/8 Dia.	5 ³ / ₄
A-2261-3		1 Dia.	6 ⁷ / ₁₆
A-2261-4		1 1/2 Dia.	
A-2261-5	2	2 1/4 x 3/8	5 ¹¹ / ₁₆
A-2261-6	3	3 Dia. x 1 W.	7 ⁹ / ₁₆

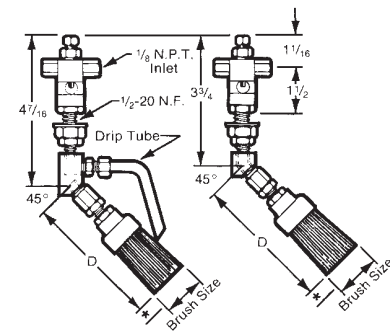

* 1/2" Adjustment for wear

Style SFGC

Model Number		Brush Size	D
W/Drip Tube	Without		
B-1008-1	B-1049-1	1/4 Dia.	4
B-1008-2	B-1049-2	5/8 Dia.	3 ⁷ / ₁₆
B-1008-3	B-1049-3	1 Dia.	4 ¹ / ₈
B-1008-4	B-1049-4	1 1/2 Dia.	
B-1008-5	B-1049-5	2 1/4 x 3/8	3 ³ / ₈

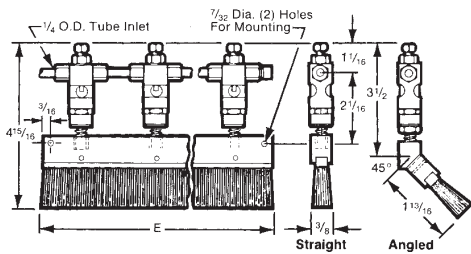

* 1/2" Adjustment for wear

Style SFGC

Model Number		E
Straight	45° Angled	
B-309-1	B-310-1	2 1/4
B-309-2	B-310-2	4 1/2
B-309-3	B-310-3	6 3/4
B-309-4	B-310-4	9
B-309-5	B-310-5	11 1/4

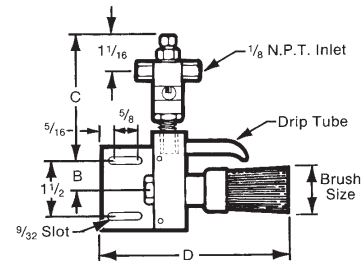

Style SFGC

Model Number	Brush Size	B	C	D
B-1009-1	1/4 Dia.	1/4	3 3/8	4 ¹³ / ₁₆
B-1009-2	5/8 Dia.			4 ¹ / ₄
B-1009-3	1" Dia.	3/4		4 ¹⁵ / ₁₆
B-1009-4	1 1/2 Dia.			
B-1009-5	2 1/4 x 3/8	3 5/8		3 1/2

Spare Parts and Accessories

Round Brush

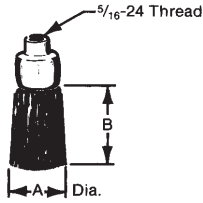

Catalog Number	A	B	Round Brush Material
A2080-2	1/4	3/4	Nylon
A2080-3	1/4	3/4	Stainless Steel
B536-2	5/8	1-1/8	Nylon
B536-3	5/8	1-1/8	Stainless Steel
B536-7	1	1-3/4	Nylon
B536-8	1	1-3/4	Stainless Steel
B536-12	1-1/2	1-3/4	Nylon
B536-13	1-1/2	1-3/4	Stainless Steel

Roto Brush

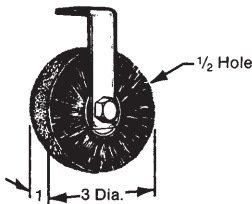

Catalog Number		Roto Brush Material
With Holder	Without	
A-2307-4	A-2440-2	Nylon
A-2307-6	A-2440-3	Stainless Steel

Flat Brush

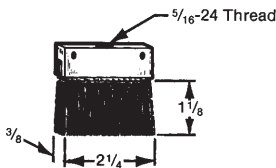

Catalog Number		Flat Brush Material
With Holder	Without	
A-2087-2	B-579-2	Nylon
A-2087-3	B-579-3	Stainless Steel

Solenoid

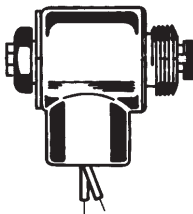

Solenoid Operator(Specify voltage Frequency)	
Model Number	B-1725

Spare Coil (Only)	
Catalog Number	Voltage and Frequency
B-2508-101	120 Volts - 60 Hz.
B-2508-102	240 Volts - 60 Hz.
B-2508-103	480 Volts - 60 Hz.
Other Voltage and Frequency Available.	

Brass Fittings

Straight Connector



Catalog Number	N.P.T.	O.D. Tube
A-4173-3	1/8	1/4

"T" Connector

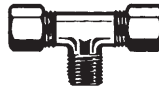

Catalog Number	N.P.T.	O.D. Tube
A-4177-2	1/8	1/4

90° L Connector



Catalog Number	N.P.T.	O.D. Tube
A-4173-31	1/8	1/4

Tubing

Clear Flexible Polyurethane Tubing



Catalog Number	O.D.	I.D.
A-4891-1	1/4	1/8

Copper Tubing



Catalog Number	O.D.	I.D.
A-4207-4	1/4	1/8

Plastic Fittings

Straight Connector



Catalog Number	N.P.T.	Barb
A-4177-45	1/8	1/8

Straight Connector



Catalog Number	N.P.T. to Barb
A-4177-14	1/8 to 1/16

Straight Connector



Catalog Number	Barb	Barb
A-4177-46	1/8	1/8

90° L Connector



Catalog Number	Barb to Barb
A-4177-44	1/8 to 1/8

"T" Connector

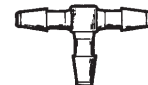

Catalog Number	Barb to Barb
A-4177-43	1/8 to 1/8

Spare Parts and Accessories

Polycarbonate Reservoirs

No Hole

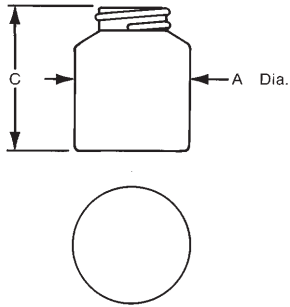

Catalog Number	Capacity	A	C
A-3515-1	1 OZ.	2	1 ¹³ / ₁₆
A-3515-2	2 ¹ / ₂ OZ.		2 ¹³ / ₁₆
A-3277-1	5 OZ.	2 ⁷ / ₈	2 ³ / ₄
A-3277-2	9 OZ.		4
B-1654-1	1 PT.	3 ⁵ / ₈	4 ³ / ₄
B-1654-2	1QT.		8 ¹ / ₈
B-2432-1	1/2 GAL.	5	9

With Hinge Lid

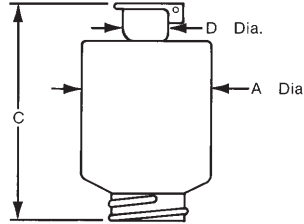

Catalog Number	Capacity	A	C	D
B-2017-1	1 OZ.	2	2 ¹ / ₈	3/8
B-2017-2	2 ¹ / ₂ OZ.		3 ¹ / ₈	
B-2017-3	5 OZ.	2 ⁷ / ₈	3 ¹ / ₁₆	5/8
B-2017-4	9 OZ.		4 ⁵ / ₁₆	
B-2017-5	1 PT.	3 ⁵ / ₈	5 ³ / ₈	1
B-2017-6	1QT.		8 ³ / ₄	
B-2017-9	1/2 GAL.	5	9 ⁵ / ₈	

Polypropylene Enclosure Caps

No Hole

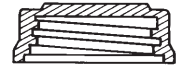

Catalog Number	Used On
B-1586-1	1 OZ. to 9 OZ.
B-2189-1	1 PT. to 1/2 GAL.

With Center Hole

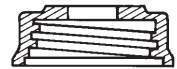

Catalog Number	Used On
B-1677-2	1 OZ. to 9 OZ.
B-2221-6	1 PT. to 1/2 GAL.

Polycarbonate Reservoir Filter

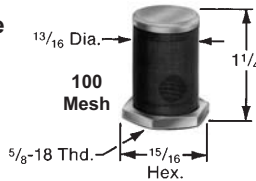

Catalog Number	Filter
A-4655-1	100 Mesh

Buna-N Gaskets For Polycarbonate Reservoirs

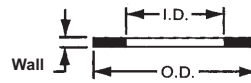

Catalog Number	Capacity	O.D.	I.D.	Wall
A-2696-2	1 OZ. to 9 OZ.	1 ¹ / ₂	1 ¹ / ₈	3/32
A-2696-10	1 PT. to 1/2 GAL.	2 ⁵ / ₈	2 ³ / ₃₂	

Acrylic and Pyrex Reservoirs

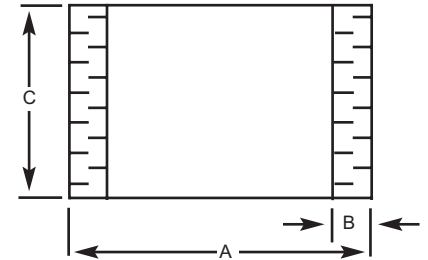

Reservoirs Pyrex				
Catalog Number	Capacity	A	B	C
A-2691-4	1 OZ.	1 ¹ / ₂	1/8	1 ³ / ₈
A-2691-6	2 ¹ / ₂ OZ.	2	5/32	1 ⁷ / ₈
A-2691-7	5 OZ.	2 ¹ / ₂	3/16	2 ³ / ₈
A-2691-8	9 OZ.	3	13/64	3
A-2691-9	1 PT.	3 ¹ / ₂	7/32	4
A-2691-10	1 QT.	4 ¹ / ₄		5
A-2691-11	1/2 GAL.	5 ¹ / ₂	1/4	7

Acrylic and Pyrex Reservoir Filter

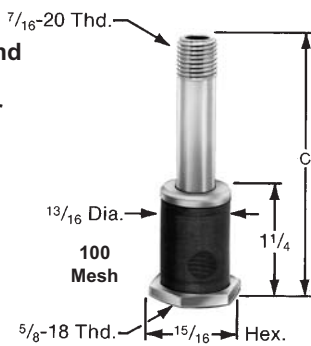

Catalog Number	Capacity	A
A-4656-1	5 OZ.	2 ¹⁵ / ₃₂
A-4656-2	9 OZ.	3 ⁷ / ₃₂
A-4656-3	1 PT.	4 ⁷ / ₃₂
A-4656-4	1 QT.	5 ⁷ / ₁₆
A-4656-5	1/2 GAL.	7 ⁷ / ₁₆
A-4656-6	1 GAL.	12 ⁷ / ₁₆

Buna-N Enclosure Gaskets for Acrylic and Pyrex Reservoirs.



Seals				
Catalog No.	Capacity	O.D.	I.D.	Wall
A-2696-2	1 OZ.	1 ¹⁷ / ₃₂	1 ¹ / ₈	3/32
A-2696-4	2 ¹ / ₂ OZ.	2 ¹ / ₃₂	1 ⁵ / ₈	
A-2696-5	5 OZ.	2 ¹⁷ / ₃₂	1 ⁷ / ₈	
A-2696-6	9 OZ.	3 ¹ / ₃₂	2 ¹⁷ / ₃₂	
A-2696-7	1 PT.	3 ¹⁷ / ₃₂	3 ¹ / ₃₂	
A-2696-8	1 QT.	4 ¹⁹ / ₆₄	3 ⁵ / ₈	
A-2696-9	1/2, 1 & 2 GAL.	5 ³⁵ / ₆₄	4 ⁷ / ₈	

Reservoirs Acrylic					
Catalog Number	Capacity	A	B	C	
A-2692-21	1 OZ.	1 ¹ / ₂	1/8	1 ³ / ₈	
A-2692-25	2 ¹ / ₂ OZ.	2		1 ⁷ / ₈	
A-2692-28	5 OZ.	2 ¹ / ₂		2 ³ / ₈	
A-2692-30	9 OZ.	3		3	
A-2692-33	1 PT.	3 ¹ / ₂		4	
A-2692-34	1 QT.	4 ¹ / ₄		5	
A-2692-36	1/2 GAL.	5 ¹ / ₂		3/16	7
A-2692-37	1 GAL.				12
A-2692-38	2 GAL.				25

Helpful information

HELPFUL HINTS FOR OPERATION AND MAINTENANCE OF CHAIN CONVEYORS AND ELEVATORS

EXCESSIVE NOISE

Possible Causes

1. Misalignment
2. Too little or too much slack
3. Improper lubrication
4. Loose casing or sprockets
5. Worn chain or sprockets

What to Do

1. Check alignment and correct
2. Adjust take-up
3. Lubricate properly (follow instructions in lubrication section)
4. Draw up all bolts...brace housings if necessary
5. Replace chain and sprocket

WEAR ON CHAIN SIDE BARS AND SIDES OF SPROCKET TEETH

Possible Causes

1. Misalignment
2. Obstruction in guides, ways or troughs

What to Do

1. Correct alignment of sprockets and shafts
2. Remove obstruction...repair or replace damaged guides, ways or troughs

CHAIN CLIMBS SPROCKETS

Possible Causes

1. Poorly fitting sprockets
2. Chain worn long in pitch...or worn out
3. Insufficient chain wrap or excessive slack
4. Material build-up in sprocket tooth pockets
5. Loose or broken buckets

What to Do

1. Replace sprockets... and chain if necessary
2. Replace chain
3. Increase chain wrap with idler or adjust center for proper slack
4. Remove material build-up
5. Tighten, repair or replace buckets

BROKEN PINS AND ROLLERS

Possible Causes

1. Conveyor speed too high for chain
2. Shock or suddenly applied loads
3. Inadequate lubrication
4. Material build-up in sprocket tooth pockets
5. Buckets striking casing

What to Do

1. Use chain of shorter pitch or sprocket with more teeth
2. Reduce shock loads...easy starts give long life
3. Lubricate properly (follow instructions in lubrication section)
4. Remove material build-up
5. Check bucket clearance with casing and tighten loose buckets

PULSATION

Possible Causes

1. Chain tension too low
2. Chain speed too slow
3. Obstruction
4. Heavy or tacky lubricants
5. Sprockets with too few number of teeth, resulting in large amount of chordal action

What to Do

1. Adjust take-ups to restore proper tension
2. Increase size of sprocket or increase conveyor speed
3. Remove obstruction and be sure lower strand is not

striking foreign obstruction, ways or trough

4. Lubricate correctly (follow instructions in lubrication section)
5. Replace with sprockets having correct number of teeth

CHAIN GETS STIFF JOINTS

Possible Causes

1. Misalignment
2. Material in chain joint
3. Improper lubrication
4. Corrosion
5. Peening of side bars
6. Excessive overloads

What to Do

1. Check sprocket and shaft alignment, and correct replace damaged chain if necessary
2. Remove foreign material
3. Lubricate properly (follow instructions in lubrication section)
4. Protect chain from corrosion with case...clean and lubricate more often
5. Check for interference between chain and another member, and correct

BROKEN SPROCKET TEETH

Possible Causes

1. Excessive shock loads
2. Objects wedged between chain and sprocket
3. Chain climbing sprocket teeth

What to Do

1. Avoid shocks...easy starts give long life
2. Remove and protect from foreign objects...alter trough at discharge point to prevent dropping of objects onto sprocket teeth
3. (Refer to Chain Climbs Sprocket)

RAPID WEAR ON TROUGHS, WAYS OR CASINGS

Possible Causes

1. Abrasive material or obstructions in troughs, ways or casings
2. Bent or damaged flights, attachments or links
3. Insufficient trough lubrication

What to Do

1. Remove obstructions and try to avoid accumulation of abrasive material
2. Replace or repair damaged flights, attachments and links
3. Lubricate properly where lubrication is permitted

DAMAGE TO CONVEYED ARTICLES

Possible Causes

1. Bent or damaged flights, attachments or links
2. Obstruction in troughs, ways or casings
3. Improper timing

What to Do

1. Repair or replace damaged parts
2. Remove obstruction
3. Check timing sequence, chain elongation, chain selection

CHAIN CLINGS TO SPROCKETS

Possible Causes

1. Incorrect or badly worn sprockets
2. Heavy or tacky lubricants
3. Material build-up in driver sprocket tooth pockets

What to Do

1. Replace chain and sprockets
2. Clean and lubricate properly
3. Remove material build-up...protect from contact with foreign material, or use sprockets with mud relief, pitch line clearance.